

Double Square Barion

Long, R.H. & Steel, N.W.

2004 USFG SSC Master Stone

Angles for R.I. = 2.20

65 + 8 girdles = 73 facets

4-fold, mirror-image symmetry

96 index

LW = 1.000 TW = 0.550 UW = 0.550

PW = 0.544 CW = 0.250

Vol./W³ = 0.387

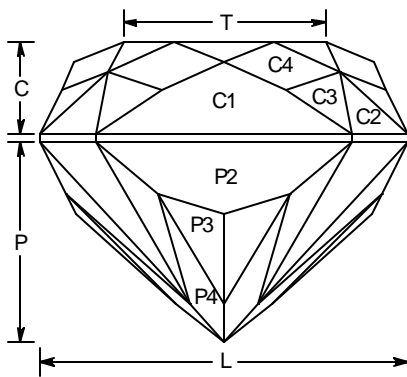

PAVILION

P1	43.12°	12-36-60-84
G1	90.00°	96-24-48-72
G2	90.00°	12-36-60-84
P2	63.42°	96-24-48-72
P3	42.39°	03-09-15-21- 27-33-39-45- 51-57-63-69- 75-81-87-93
P4	41.00°	06-18-30-42- 54-66-78-90

CROWN

C1	65.00°	96-24-48-72
C2	48.18°	12-36-60-84
C3	43.50°	07-17-31-41- 55-65-79-89
C4	37.00°	06-18-30-42- 54-66-78-90
C6	27.33°	12-36-60-84
C5	22.00°	96-24-48-72
T	0.00°	Table