

UNITED STATES FACETERS GUILD

Promoting the art, skill and teaching of faceting • Expanding the knowledge of natural & man-made crystals
Developing & promoting uniform rules for faceting competitions everywhere • Sponsoring or assisting in managed competitions
Serving as a national repository for faceting designs, published materials & information

2014 SINGLE STONE COMPETITION GUIDE

NOVICE



SIMPLE HEART

Designed by: Jeff Graham

PRE-MASTER



TRI-HEART

Designed by: Robert Strickland

MASTER



HEART OF NINES

Designed by: Robert Strickland



2013 SINGLE STONE COMPETITION RESULTS

NOVICE

SCORE	PLACE	FIRST	LAST	LOCATION
99.8081	1	Kathryn	Hitchcock	VA
99.0404	2	James	Cockrell	TX
98.4646	3	Jared	Sprague	NC
97.697	4	Dale	Ruperd	ID
97.697	5	Randall	Lantz	TX
97.1212	6	Thomas	Marcum	IN
96.9293	7	James	Ingersoll	CO
95.7778	8	Tom	Mitchell	FL
95.7778	9	Audrey	Szymborski	MI
95.0101	10	Bruce	Rothman	CA
94.0505	11	Glenn	Wood	PA
93.4747	12	Vlad	Tsikhotskyy	WA
92.7071	13	Randy	Eggert	WA
90.404	14	Dave	Wester	WA
89.2525	15	Galen	Perry	LA
89.2225	16	John	Bayer	NC
88.4848	17	Larry	Boles	CA
87.3333	18	Peter	Clark	MS
87.1414	19	Wayne	Wilson	TX
82.9192	20	Don	Sabie	AR
81.7676	21	Dana	Piozet	ID
80.0404	22	Kathy	Jenkins	IN
79.4646	23	Mari	Webb	FL

PRE-MASTER

SCORE	PLACE	FIRST	LAST	LOCATION
99.6287	1	Michael	O'Neill	WA
99.2573	2	Patrick	DuBuc	Quebec
95.7296	3	Larry	Drake	TN
92.9445	4	Fred	Cerwick	NE
92.0162	5	Steve	Page	HI
91.6448	6	Susan	Lichtenberger	KY
91.4591	7	Kate	Pleatman	OH
88.6741	8	Rita	Phagan	NC
87.9314	9	Sandra	Hartman	MI
87.7457	10	Barb	Yost	MI
87.0003	11	Elaine	Songer	FL
86.6317	12	Eric	Hoffman	MD
86.2604	13	Bruce	Argall	PA
86.0747	14	Alain	Roelandts	France
82.3613	15	Deborah	Drake	TN
81.6186	16	Jim	Marks	NV
80.8759	17	Greg	Stimpson	IL
78.2765	18	Bill	Poland	FL
77.5338	19	Albert	McBee	OK
77.3482	20	Frank	Toth	VA

MASTER

SCORE	PLACE	FIRST	LAST	LOCATION
100.0000	1	Terry	Wilhelm	OH
98.7241	2	Aleksandar	Zunic	Serbia
97.4482	3	Homer	Barrs	FL
97.4482	3	David	Echols	AL
97.0836	4	Lynn	Goulet	ND
96.7191	5	Anonymous	—	Hong Kong
93.8027	6	Caitlin	Ninedorf	WI
92.1623	7	Dan	Lynch	TN
87.7878	8	Anonymous	—	MD

GRAND MASTER

SCORE	PLACE	FIRST	LAST	LOCATION
99.2709	1	Dick	Fairless	MI
99.2709	1	Anthony	Burston	UK
98.9064	2	Charles	Lundstrom	AZ
98.5418	3	Denny	Bradley	MO
97.6305	4	Michiko	Huyhh	CA
95.0787	5	Greg	Ninedorf	TX
94.7141	6	Gulay	Ertan	Turkey

This article serves as
**AN INVITATION FOR INTERESTED MEMBERS OF
THE UNITED STATES FACETERS GUILD**
to enter the
2014 USFG SINGLE-STONE COMPETITION

The Single-Stone Competition program, with Novice, Pre-Master, Master and Grand Master Classes, will be conducted as a typical single-stone competition in which winners of the classes will be recognized and presented awards.

NOVICE CLASS

To certify as a USFG Novice, an inexperienced faceter must achieve a score of 85% or higher on the Novice design. A score of 90% or higher will qualify the faceter to enter the Pre-Master class competition. Cutters who score 90% or higher and wins the Novice must move up to Pre-Master Class.

PRE-MASTER CLASS

To certify as a USFG Pre-Master, the faceter must make a minimum score of 90% on cutting the Pre-Master design. A score of 93% or higher will qualify the faceter to enter the Masters Class competition. If the cutter scores 93% or above and places first they must move up to Master Class.

MASTER CLASS — MASTER DIVISION

To certify as a USFG Master the faceter must make a minimum score of 93%. Any faceter who has not won a previous Masters competition and has never competed in the Australian Challenge may enter the USFG Master Class — Master Division. Cutters who score 95% or higher and win in Master must move up to Grand Master Class.

MASTER CLASS — GRAND MASTER DIVISION

Any faceter who has won a previous Masters competition must enter in the Grand Master Division. This includes any faceters who have participated in the Australian International Faceting Challenge, by which entry — with no exceptions — they are automatically classified as Master faceters. Any cutter who has scored 95% or higher in USFG Masters Class may cut for the Grand Master. Any cutter who has scored

95% and won a USFG Masters Class must cut for the Grand Master. Note the Grand Master Division will cut the same stone as the Master Class

AWARDS

In general, awards will be given to cutters scoring 1st, 2nd, and 3rd place in the Novice, Pre-Master, Master and Grand Master class. Types of awards and certificates will be determined and published with each competition announcement, with the approval of the USFG BOD. In the unlikelihood of exact ties and spirit of fair competition all scores resulting in ties will receive like awards.

ELIGIBILITY FOR AWARDS

To be considered for awards in a particular class, cutters must meet the following minimum criteria.

- **Novice** Score 90% or higher in a USFG Novice competition.
- **Pre-Master** Score 93% or higher in a USFG Pre-Master competition.
- **Master** Score 95% or higher in USFG Master competition.
- **Grand Master** Score 98% or higher in USFG Grand Master competition.

ELIGIBILITY FOR CERTIFICATION

To be considered for certification in a particular class, cutters must meet the following minimum criteria.

- **Novice** Score 85% or higher in USFG Novice competition.
- **Pre-Master** Score 90% or higher in USFG Pre-Master competition.
- **Master** Score 93% or higher in USFG Master competition.

CERTIFICATE OF PARTICIPATION

All cutters not eligible for awards or certification will receive certificates of participation.

ADDITIONAL COMPETITION NOTES

1. All competitors will receive a certificate (*suitable for framing*) of achievement from the USFG Competition committee. The wording on each certificate will reflect the competitor's accomplishment.
2. Once a Cutter has been certified in any USFG competition, that certification will remain permanent, even if the faceter, when re-cutting in his or her certified class/division, scores below the minimum certification score.
3. This competition is **ONLY** open to members of the United States Faceters Guild.
4. **Anonymous Entry** — If a cutter enters a single stone competition, under the 'Anonymous Entry' provision, the fee shall be the same as a normal entry. The cutter will be treated as any other entrant and only the score shall be considered for publication. The only person that will be held in confidence will be the one stone handler assigned by the competition committee that disperses the stones to the judges. This is a controversial concept as some competitions are held anonymous with only the winner published and some demand all entrants be published; at another time this rule could change, but for now it will be open to either entrant. To enter as "Anonymous" cutters shall submit a written request (*or signed entry form indicating this desire*) accompanied with the stone and full Single Stone Competition fees. All other conditions for entry shall apply, i.e., return postage, entry deadlines, etc
5. **Publication of scores** — At the discretion of the competition committee scores may be published in the USFG newsletter, USFG web site, and/or public venues supported/sponsored by the USFG; including reciprocal agreements with other guilds.
6. For reasons of sensitivity the competition committee may choose to exclude the publication of low scores from publication.
7. Anyone who wished to remain anonymous shall remain so. However the competition committee may report the anonymous cutters score only as "Anonymous Entry".
8. **Privacy** — The USFG will only publish data pertaining to a cutter's; name, score, city, and/or state (*or country*). No other data including mailing addresses, telephone numbers, or e-mail addresses shall be made to the general USFG membership or greater public.
9. The names of cutters (*and scores of stones*) that are disqualified or determined to be ineligible, for whatever reason, will be reported to the USFG-BOD, but not to the general USFG membership or public.

SHIPPING AND HANDLING INSTRUCTIONS

1. Place the stone in a 1½" diameter round plastic gemstone display cup with the foam insert and cap. **Please do not mark or identify the gem or container in any way.** If gem containers are marked or identified the competition coordinator may choose to repackage the stone in a generic container.
2. Place the following in a bubble protected envelope:
 - a. The display cup containing the stone.
 - b. An additional bubble protected self addressed and stamped envelope for return. The use of a 6" x 9" bubble envelope (*or larger envelope/box*) is suggested to help accommodate the return of scoring materials.
 - c. Entry Fee: **All classes — ENTRY IS FREE!!**
 - d. Completed and signed entry form. Feel free to photo copy forms as needed.
3. Mail the package to:

**Mr. Jeff Ford
2410 North 2nd Street
Kalamazoo, MI 49009**
4. At the participant's discretion, packages may be sent by certified mail and/or insured. It is suggested that non-US entries use insured mail if possible.
5. Stones will be returned to the cutter in the manner of the return postage. If no specific instructions or if required postage is not received with the entry, USPS first class mail will be used for returning cutters stones and judging materials.
6. **THE POSTMARK DEADLINE FOR SUBMITTING THE STONES IS ** JUNE 20, 2014**** Stones received with later post marks may be subject to exclusion from the competition.

7. The stone handler will code the stone(s) for anonymity, repack, and send the stone to a selected judge. The judged stone and comprehensive “*mark-up-sheet*” will be returned to stone handler who will decode and repackage the stone with the score sheet and return to the individual contestant. The expected date of return is generally late July.
8. **Note:** The United States Faceters Guild or stone handler shall not be held liable for stones lost or damaged in the course of shipment. In general the stone handler and judges will use USPS Priority Post with nominal insurance for the shipment of stones between the stone handler and judges.
6. **Meet Points** A point where 4 or more facets culminate in a perfect point with no facet over cut and/or no facet under cut. Note every meet, regardless on the number of facets carries the same scoring weight.
7. **Chips** Areas where pieces of material have been chipped off unintentionally. They usually occur along facet edges, at corners, and/or culets.
8. **Girdle Uniform** Facets in the same series around a faceted girdle shall be the same shape and dimensions. Girdle facets shall be an exact replica of the girdle on the pattern. Cutters may lose points if the overall girdle is uneven, tilted, or skewed, but within the stated tolerances of the girdle thickness.

GENERAL JUDGING RULES

Categories are the same numerical order as score sheet:

1. **Scratches** Each facet shall be absent of scratches including the finest of cat hairs. Inclusions or fractures that surface and look like scratches will be judged under this feature.
2. **Pitting** Each facet shall be absent of pits including the tiniest inclusions and fractures that surface and look like pits will be judged under this feature. Foreign matter on the surface that will not wipe off will be judged as an error. Flaws, fractures, cleavages, partings, and inclusions will be judged under category 1 or 2 on the score sheet if they surface.
3. **Grooved Facets** Facets that show grooving in the polish when held just between shadow and shine. Herringbone effect in Quartz can sometimes show up in the polish in the same manner. Both features will be judged in this category.
4. **Flat Facet and Sharp Edges** Facet surface true — this refers to the flatness of facets or unevenness of curved facets. Unintentional facets and ghost facets will be penalized under this feature. Facet edges sharp — The junction between facets should be knife-edge. Both of these features will be judged under category 4 on the score sheet. Chipped edges will be judged under the category for chips, not under this feature.
5. **Facet Uniform** Refers to consistency in shape and size of facets in the same series. Facets must also have consistency with the pattern & plan views.
9. **L/W Ratio** The length to width ratio will be on the design and score sheets — variance of 0.1 mm +/- will be allowed without deduction. If out, a 3 point 100% error will result. The actual Length dimension used for calculation will be based upon the cut Width of the stone.
10. **Stone Width** The competition committee will set the stone width. Without question this will be clearly indicated on the pattern used for competition. Unless noted, there will be an allowable margin of 0.1 mm more or less than the stone width set by the committee. The Competition Committee will designate stone widths between 6 mm and 15 mm. If out, a 3 point 100% error will result.
11. **Girdle Thickness** Girdle thickness shall be 0.3 mm +/- 0.1 mm. If the pattern has a scalloped girdle, the thin part of the scallop should not be less than 0.2 mm or greater than 0.4 mm. If out, a 3 point 100% error will result.

ADDITIONAL JUDGING NOTES:

1. Categories 1,2,3,4, and 7 represent polish.
2. The girdle shall be polished and judged under the same categories on the score sheet, “1 through 7” as with all other facets. Two other categories are specifically designated for the girdle alone. They are 8 — “*Girdle Uniform*” and 11 — “*Girdle Thickness*”.
3. **Scoring in Categories 1 through 8** errors will be assigned a weighted value of 25%, 50%, or 100% point deduction depending upon the magnitude of the error. A general definition of the weighted value scoring is

as follows: 25% off if the error is barely visible with a 10X loupe, 50% off if the error is easily seen with a 10X loupe, or 100% when a most serious error is seen with the 10X loupe and/or if the error can be seen with the naked eye.

4. **Scoring in Categories 9 through 11** errors will be automatically assigned a 3 point 100% deduction.
5. **The Plan View** — it is an important serious parameter of evaluation in a faceting competition. The definition: “A plan view is that arrangement of meets and lines one sees when looking directly down or up the vertical axis portrayed on a cutting pattern/diagram.” The following are examples of how a cutter may create a change in “plan view” when cutting a competition stone: The most frequent is, deliberately creating a change in the “plan view” when cutting a competition stone — in jeopardy by employing a severe change of angle or angles that will create a non-design facet(s) — this comes under the judges prerogative for making the decision, and/or without question, a mishap of inadvertently leaving out a tier of facets. Both crown and pavilion are subject to penalty if the plan view of either one is in error. If the plan view as defined is not followed in the opinion of

the judge, then in all cases the stone will be **ineligible** and the judge will give written reasons on the judging sheet.

6. Angles are not normally judged in USFG competition; cutters should feel free to Tangent-Ratio angles (*within reason*) as needed or desired. This may be done for personal preferences relating to optical performance, adjustments needed for the conservation of material, etc.
7. Pre-judging of stones is strictly forbidden. Any indication of pre-judging will automatically — **without exception** — disqualify the participant from the competition. Pre-judging is loosely defined as having a stone evaluated for errors (*by another cutter/mentor*) in a manner that allows the cutter to go back and make corrections.
8. The minimum final score a judge will award is 50 out of 100 possible points.

Any questions about the competition should be directed to:

**Mr. Jeff Ford, 2410 North 2nd Street
Kalamazoo, MI 49009**

 jeffinkzoo@sbcglobal.net

2014 USFG SINGLE-STONE COMPETITION — NOVICE

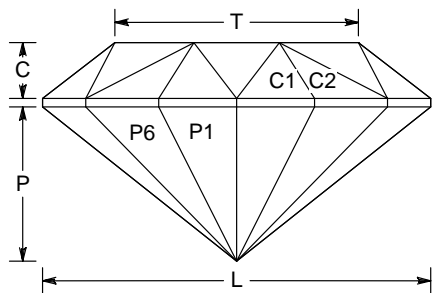
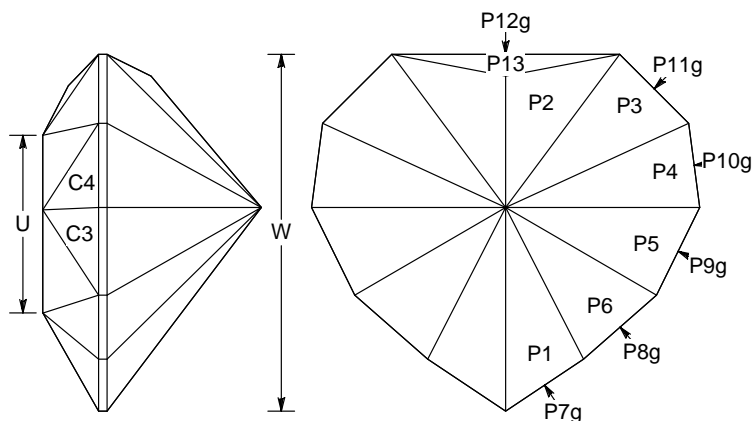
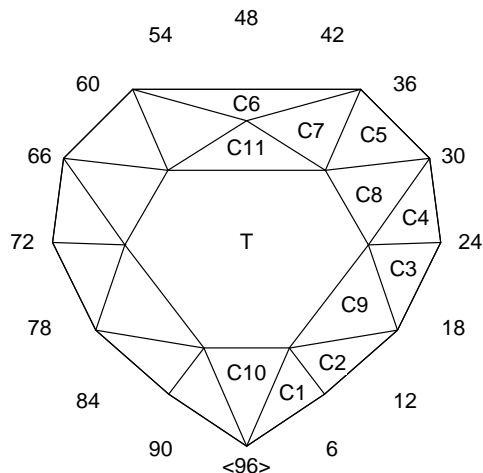

SIMPLE HEART

By Jeff Graham — used with premission

2014 USFG SSC Novice Stone

Angles for R.I. = 1.540

31 + 11 girdles = 42 facets

1-fold, mirror-image symmetry

96 index

$L/W = 1.088$ $T/W = 0.682$ $U/W = 0.498$

$P/W = 0.432$ $C/W = 0.157$

$Vol./W^3 = 0.220$



Raytracing of design performed with Robert Strickland's GemRay™ for Windows™

PAVILION

P1	42.32°	09-87	Cut to center point
P2	40.98°	44-52	Cut to center point
P3	39.21°	36-60	Cut to center point
P4	38.70°	26-70	Cut to center point
P5	41.53°	17-79	Cut to center point
P6	43.00°	11-85	Cut to center point
P7g	90.00°	09-87	Cut to meet P1
P8g	90.00°	11-85	Cut to meet P6
P9g	90.00°	17-79	Cut to meet P5
P10g	90.00°	26-70	Cut to meet P4
P11g	90.00°	36-60	Cut to meet P3
P12g	90.00°	48	Cut to meet P2
P13	63.55°	48	Cut to meet P12g

CROWN

C1	44.00°	09-87	Cut to meet girdle
C2	44.00°	11-85	Cut to meet girdle
C3	41.20°	17-79	Cut to meet girdle
C4	37.81°	26-70	Cut to meet girdle
C5	34.20°	36-60	Cut to meet girdle
C6	44.00°	48	Cut to meet girdle
C7	33.38°	46-50	Cut to meet girdle
C8	30.12°	32-64	Cut to meet girdle
C9	36.69°	14-82	Cut to meet girdle
C10	29.65°	96	Cut to meet girdle
C11	27.32°	48	Cut to meet C6, C7
T	0.00°	Table	Cut to meet C8-C11

Material: Cutters Choice — any color
 Width: 10 – 12 mm
 Girdle: 0.3mm | +/- 0.1mm

2014 USFG SINGLE-STONE COMPETITION — PRE-MASTER

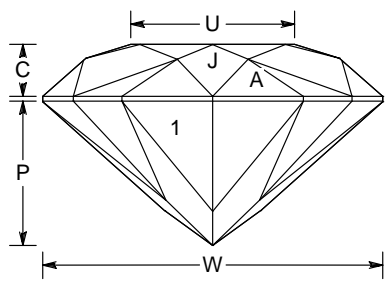
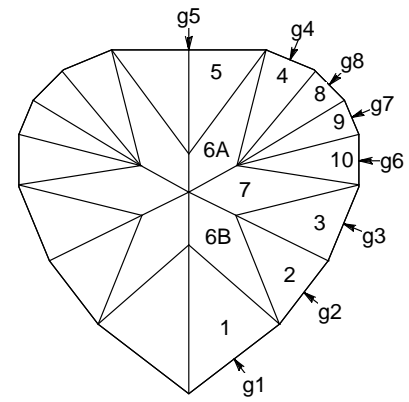
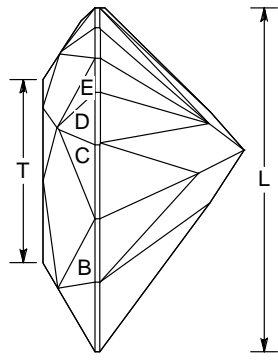
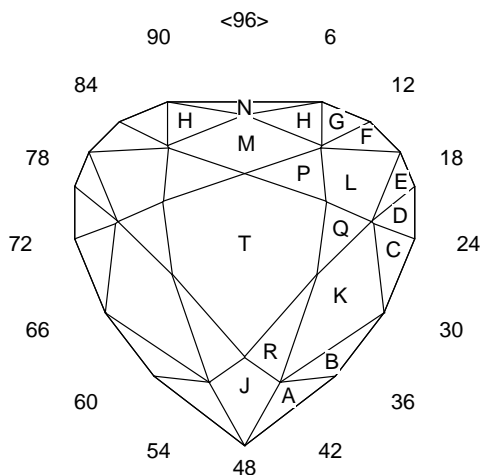

TRI-HEART

By Strickland, Robert W: TFG Newsletter, Oct 93, v14n4p23

2014 USFG SSC Pre-Master

Angles for R.I. = 1.720
 52 + 15 girdles = 67 facets
 1-fold, mirror-image symmetry

96 index

L/W = 1.012 T/W = 0.538 U/W = 0.481
 P/W = 0.424 C/W = 0.153
 Vol./W³ = 0.200



Raytracing of design performed with Robert Strickland's GemRay™ for Windows™

PAVILION

1	43.00°	38-58
2	44.40°	34-62
3	43.90°	30-66
4	42.68°	06-90
5	45.40°	01-95
6A	42.45°	04-92
6B	42.45°	36-60
7	41.50°	28-68
8	41.55°	12-84
9	41.03°	18-78
10	41.70°	24-72
g1	90.00°	38-58
g2	90.00°	34-62
g3	90.00°	30-66
g4	90.00°	06-90
g5	90.00°	96
g6	90.00°	24-72
g7	90.00°	18-78
g8	90.00°	12-84

CROWN

A	52.30°	38-58
B	42.90°	34-62
C	39.31°	30-66
D	41.40°	24-72
E	35.54°	18-78
F	33.60°	12-84
G	39.46°	06-90
H	37.54°	01-95
J	30.40°	48
K	34.00°	32-64
L	30.30°	14-82
M	32.90°	96
N	47.06°	96
P	18.80°	05-91
Q	16.40°	26-70
R	18.70°	35-61
T	0.00°	Table

Material: Synthetic Spinel — any Color
 Width: 10 – 12 mm
 Girdle: 0.3mm | +/- 0.1mm

2014 – USFG Single Stone Competition Cutting Review

For the 2014 USFG Single Stone Competition patterns we are using a heart theme. I did have some feedback about heart pattern and novice cutters being a bit of an oxy-moron? Perhaps, but I think we have a fairly easy one for the novice as far as hearts go. To help a bit we have set the width of all classes to 10 – 12mm. For the PreMaster and Master patterns we looked to Robert Strickland for a couple of challenging patterns.

Novice Pattern – Simple Heart by Jeff Graham
Material – Cutters Choice, any color

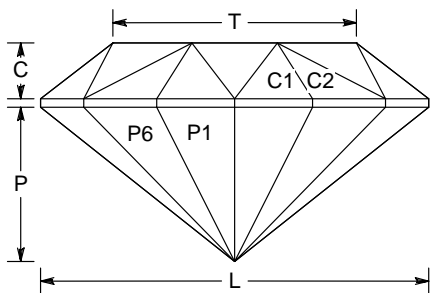
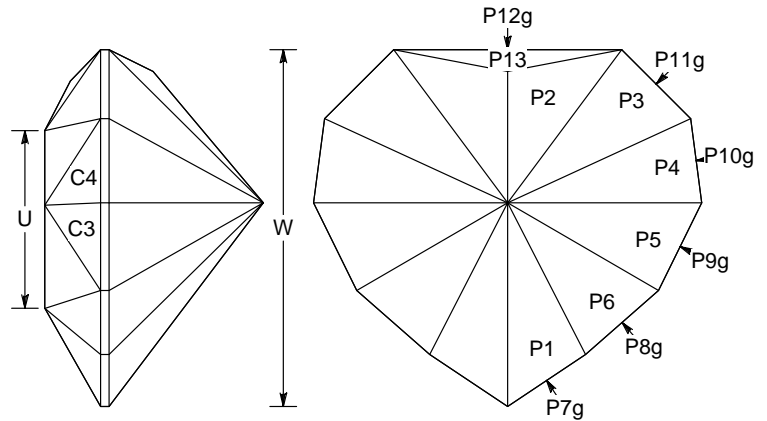
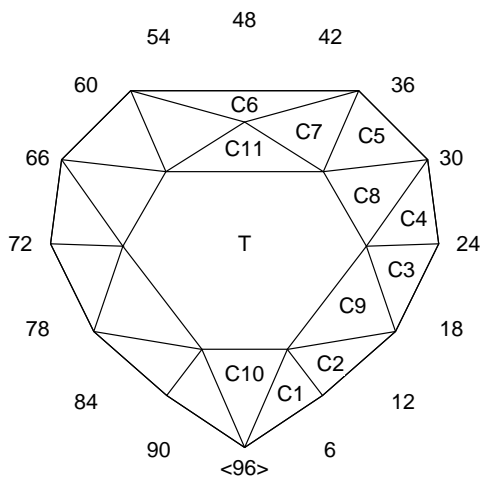

Raytracing of design performed with Robert Strickland's GemRay™ for Windows™

We are lucky with this one that there is a very comprehensive review on Rockhounds.com. Special thanks to both the Graham family and Bob Keller for use permissions.
http://www.rockhounds.com/rockshop/gem_designs/cutting_sapphires/index.shtml
http://www.rockhounds.com/rockshop/gem_designs/simple_heart/index.shtml

PreMaster - Tri-Heart by Robert W. Strickland
 Texas Faceters Guild Newsletter, Oct 93, v14n4p23
 Material – Synthetic Spinel, any color

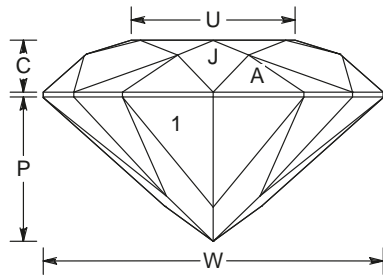
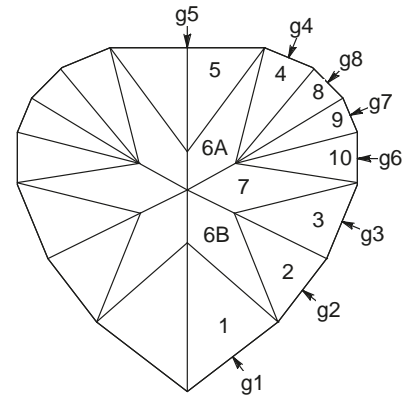
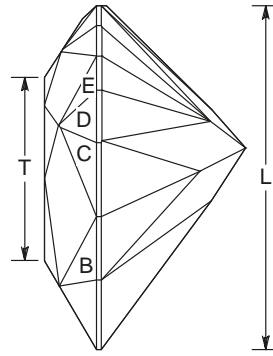
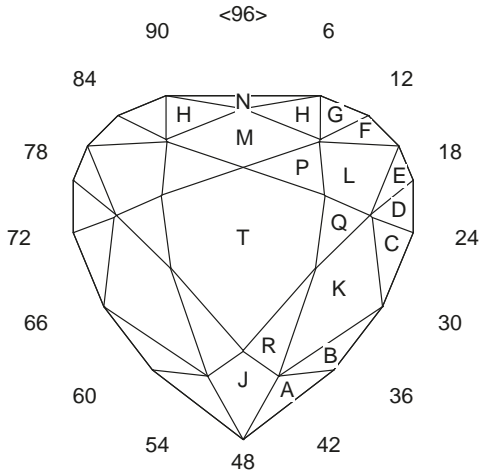

Raytracing of design performed with Robert Strickland's GemRay™ for Windows™

Master / Grand Master Pattern - Heart of Nines by Robert W. Strickland
Texas Faceters Guild Newsletter, Jan 95, v16n1p18
Material – Synthetic Corundum, any color

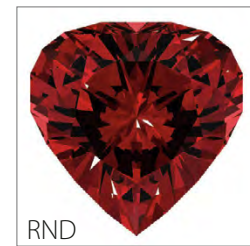
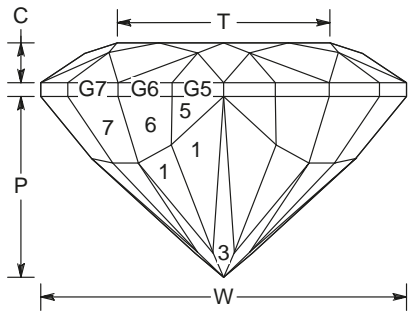
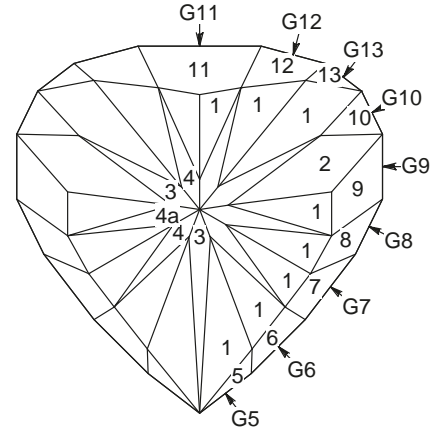
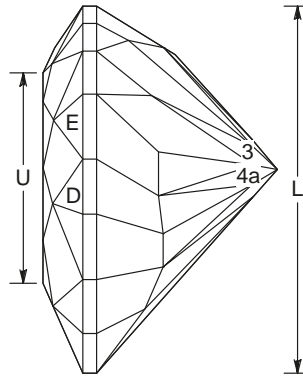
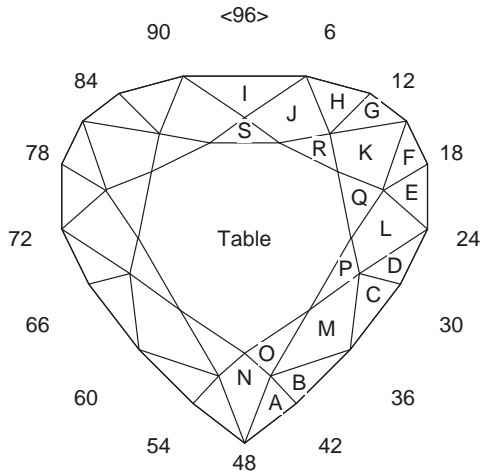

Raytracing of design performed with Robert Strickland's GemRay™ for Windows™

USFG SINGLE STONE COMPETITION ENTRY FORM

Please include a signed copy of this form with your stone, entry fee, return packaging and return postage, a 6" x 9" bubble padded envelope or box is recommended for return.

Please use a 1-1/8" clear stone cup if possible. Entry Deadline is June 20, 2014

Entries may be mailed to: Mr. Jeff Ford, 2410 N 2nd St, Kalamazoo, MI 49009

Name:				
Address:				
City/zip (country)				
Phone:				
Email:				
<p>The most common questions about the USFG Single Stone Competition:</p> <ol style="list-style-type: none"> 1. This is a closed competition; cutters MUST be current members of the USFG. Membership application/fees/renewals may be submitted with the cutters entry. 2. This is a single stone event; one cutter, one class, one stone. Cutters may not enter multiple stones and/or classes. 3. Cutters may not enter stones in classes below prior certifications levels. 4. Cutters may challenge higher classes, BUT it is highly recommended that they have another cutter honestly evaluate their cutting skills before doing so. 				
Entry Class (circle one)	Novice	PreMaster	Master	Grand Master
Entry Fee (US funds)	**FREE**	**FREE**	**FREE**	**FREE**
Stone Data (if known)	Stone Size, mm		Stone Color	
	Stone Species		Stone Weight	
Faceting Machine used? (optional)				
Entry Type ? (circle one)	Anonymous Entry - Yes, I wish to enter as "Anonymous" Note: Scores still may be reported, but only identified as "Anonymous Entry"		Public Entry - Yes, I wish to have my name & score "Public" and reported as such.	
<p>Note: All cutters (Anonymous or Public) will be entitled to receive awards and/or certification for qualifying scores. If NO selection is made above, it will be assumed that the cutter wishes to enter their stone entered as "Public Entry"</p>				
Signature / Date				
<p>Your signature indicates that you accept the Rules & Conditions of USFG competition. Complete USFG Single Stone Competition rules may be found at http://www.usfacetersguild.org/docs/CurrentSSCRules.pdf</p>				

USFG MEMBERSHIP APPLICATION

Membership to the USFG is open to faceters or people interested in faceting everywhere. Our primary goal is to improve the art and science of faceting through our newsletter and correspondence. Our secondary goal is to improve competitions and competition rules both in the U.S. and internationally. Officers are elected every two years for two year terms, taking place in even years. Members will receive our Quarterly Newsletter — usually about 20 pages each, and the right to participate in USFG activities. The By-Laws of the USFG may be reviewed at our website: <http://www.usfacetersguild.org/docs/USFGbylaws.pdf>



Name _____ Date _____

Street Address _____ Telephone _____

City, State, Zip _____ E-mail _____

I am interested in becoming a faceter _____ I have been faceting for _____ yrs

I have a display case ___ 12 stones ___ 20+ stones ___ Educational ___ Other _____

Competition experience/ Certifications: Junior ___ Novice ___ Intermediate/PreMaster ___ Master _____

Which machine(s) do you cut with? _____

Do you cut commercially? _____ Are you a dealer? _____

Have you given talks or written articles on faceting? _____

Special talents or interests to share? _____

**** Membership (all locations) is \$18 USD for one (1) year - please remit US funds only. ****
As a convenience members may choose to renew for multiple years at \$18 per year

Please make checks payable to the "USFG" Mail this form with payment to:	Newsletter Delivery Format Downloadable via the web Adobe PDF - Portable Document Format March – June – September - December Email notification will be sent to current members with password to open the document.
USFG Treasurer c/o Jeff Ford 2410 N 2nd St Kalamazoo, MI 49009	E-mail for the Editor: editor@usfacetersguild.org
E-mail for the Treasurer: treasurer@usfacetersguild.org	E-mail for the Editor: editor@usfacetersguild.org
Please feel free to copy or use the back of this form for additional information or special instructions.	
Membership questions may be sent to Jeff Ford or membership@usfacetersguild.org	
Please circle one	
<input type="checkbox"/> New Membership	<input type="checkbox"/> Renewal
<input type="checkbox"/> Returning Member	