

# 2019 Grand Master Design

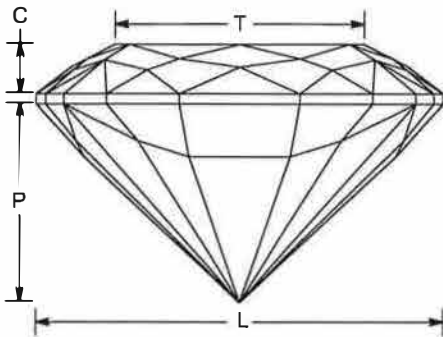
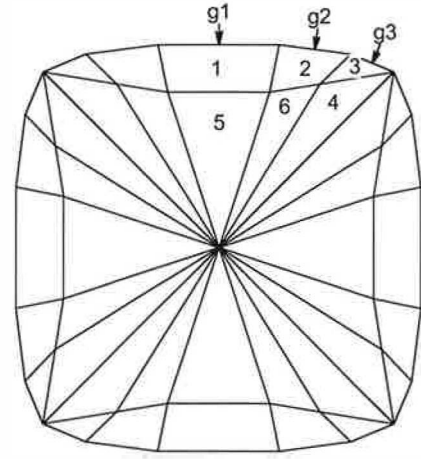
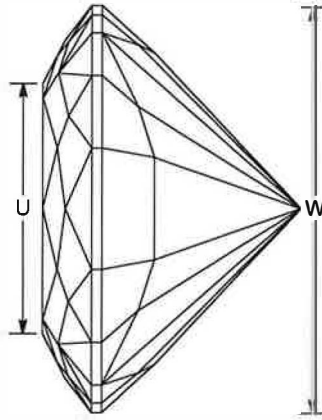
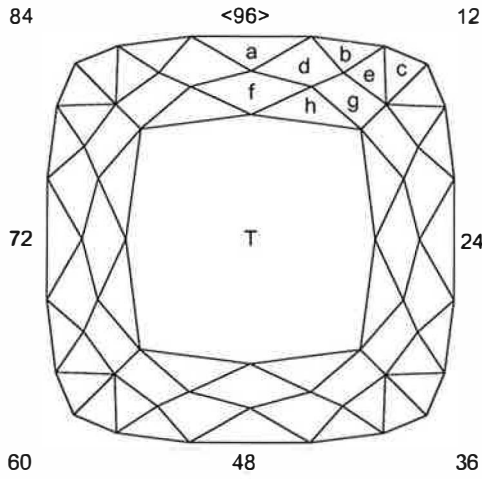

## Prince of Portugal

By Ernie Hawes

Angles for R.I. = 1.760

97 + 20 girdles = 117 facets

4-fold, mirror-image symmetry 96 index

L/W = 1.000 T/W = 0.613 U/W = 0.613

P/W = 0.487 C/W = 0.121

Vol./W<sup>3</sup> = 0.257

### PAVILION

g1	90.00°	96-24-48-72	Set stone size
1	47.90°	96-24-48-72	Create temporary center point (TCP)
2	47.40°	02-22-26-46-50-70-74-94	Cut close to TCP so g1 is about 1/3 width of stone
g2	90.00°	02-22-26-46-50-70-74-94	Cut level with g1 joining at corners
3	42.80°	06-18-30-42-54-66-78-90	Cut permanent center point (TCP) so 1/2 g2 is left
g3	90.00°	06-18-30-42-54-66-78-90	Cut level with g2 & meet 3 at corner
4	40.01°	07-17-31-41-55-65-79-89	Cut to PCP & meet 3 at the girdle
5	43.00°	96-24-48-72	Cut to PCP
6	41.75°	03-21-27-45-51-69-75-93	Ease in to PCP & meet at juncture of 3 & 4 & 1, 2 & 5

### CROWN

a	37.50°	96-24-48-72	Set girdle thickness
b	36.50°	02-22-26-46-50-70-74-94	Cut to level girdle line with a
c	32.25°	06-18-30-42-54-66-78-90	Cut to level girdle line with b
d	34.60°	01-23-25-47-49-71-73-95	Meet a & b at the girdle
e	31.55°	05-19-29-43-53-67-77-91	Meet b & c at the girdle
f	27.25°	96-24-48-72	Meet at juncture of a & d
g	27.05°	04-20-28-44-52-68-76-92	Meet at juncture of d & e
h	22.00°	02-22-26-46-50-70-74-94	Meet at juncture of d, f & g
T	0.00°	Table	Meet at juncture of f & h & g & h

Material to Cut: Topaz

Width: 12.0 mm +/- 0.1 mm

Girdle: 0.3 mm +/- 0.1 mm

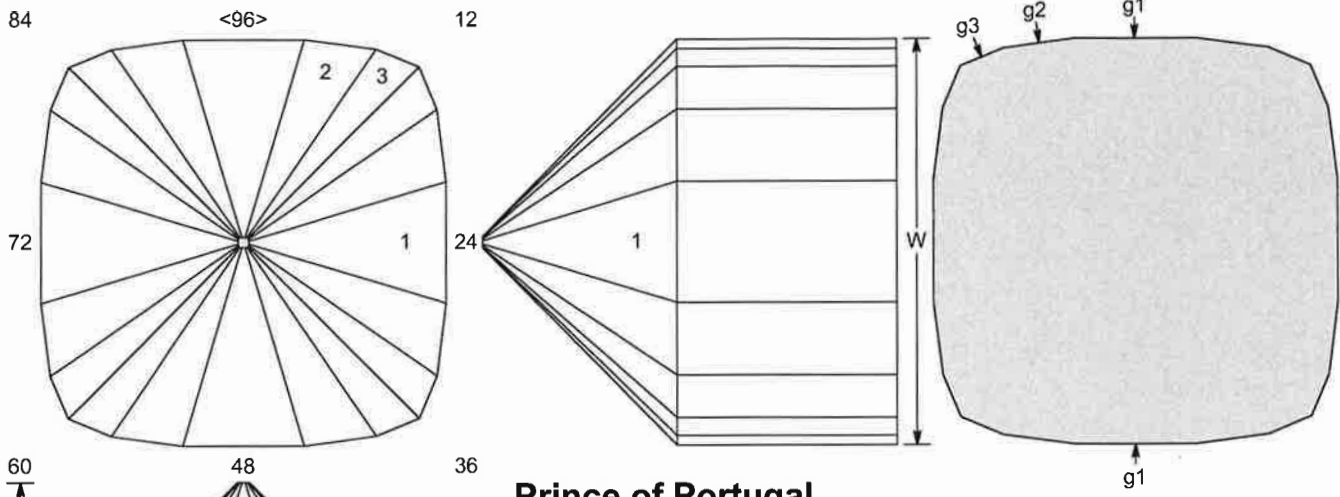

**Prince of Portugal**

By Ernie Hawes  
 CAM Preform by Jeff Theesfeld  
 Angles for R.I. = 1.760  
 20 + 20 girdles = 40 facets  
 4-fold, mirror-image symmetry  
 96 index  
 L/W = 1.000  
 C/W = 0.479  
 (g1 g1)/W = 1.000  
 Vol./W<sup>3</sup> = 0.654

**PREFORM**

1	44.52°	96-24-48-72	Cut to TCP
2	43.66°	02-22-26-46- 50-70-74-94	Cut to TCP
3	41.00°	06-18-30-42- 54-66-78-90	Cut to TCP
g1	90.00°	96-24-48-72	Set stone size for final 12 mm
g2	90.00°	02-22-26-46- 50-70-74-94	Meet 1 and g1
g3	90.00°	06-18-30-42- 54-66-78-90	Meet 2 and g2